

Kitchen Cabinets (base)

ASSEMBLY INSTRUCTIONS

DCB3612 and DCB3309

PARTS LIST: A – Big Frame (1 piece)
 B – Side Panel (2 pieces)
 C – Bottom with Round Panel (1 piece)
 D - Toe Kick (2 pieces)
 E – Back Panel (2 pieces)

F – Shelf with Round Panel (1 piece)
 G - Connected Door H – Hardware Box (1 piece):
 cam locks
 metal screw dowels
 wooden dowels
 back screws
 caps

TOOL LIST:
 Phillips screwdriver
 (or Cordless drill with
 phillip tip, optional)

(1)

Start with Panel **B** and insert camlocks and dowels into appropriate holes.

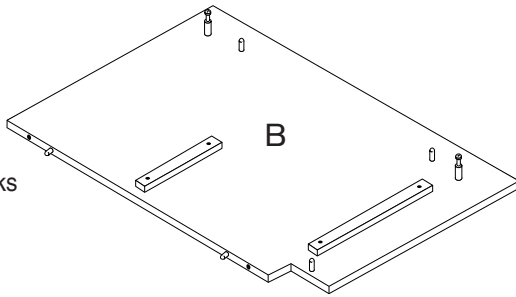

(2)

Assembly toe panels and add Panel **E** to **B** panel.

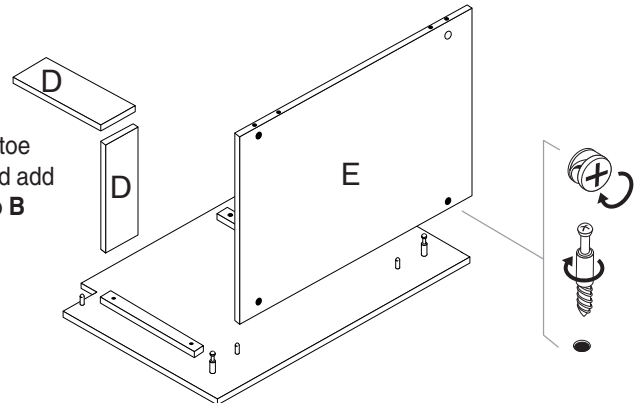

(3)

Add second Panel **E** to nearly completed base.

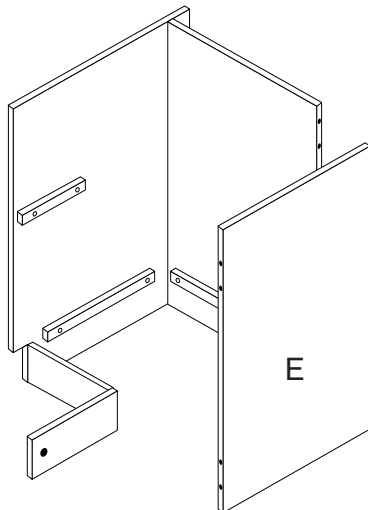

(4)

Add **C** to floor. Assembly door structure (**A & H**) and affix to front.

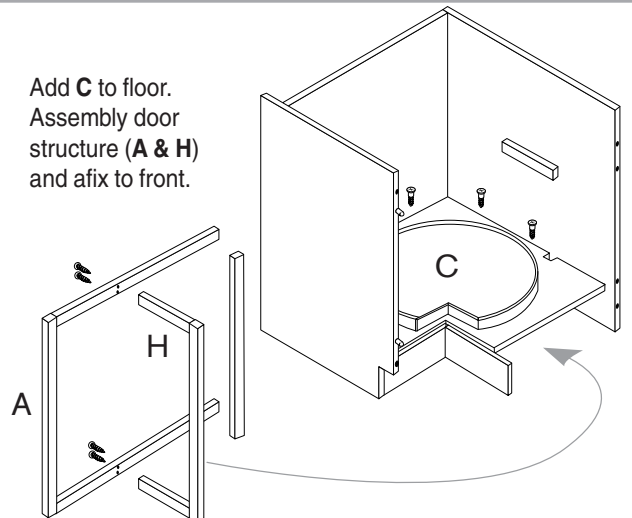

(5)

Add **B** to enclose cabinet structure.

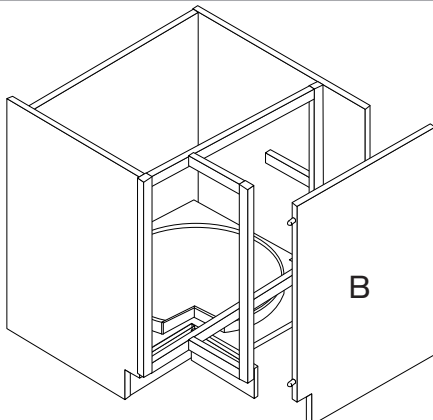

(6)

Add doors (**G**), use final screws to affix top panels, and then place **F** in center of top panel.

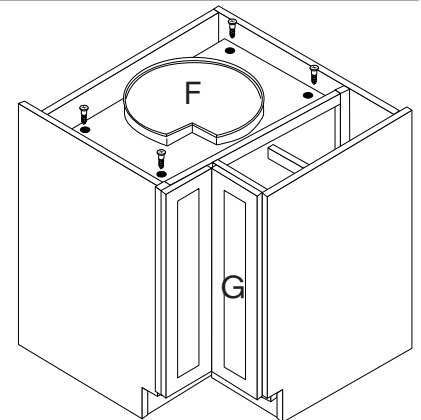

TIPS: Don't rush the assembly, get it right the first time. Test fit first before locking anything down. Don't over tighten the cam locks and only use a screw driver on them, since a cordless drill could have too much torque and break the cam.